

NORD P&D On-The-Fly Gate

The NORD P&D On-The-Flight Gate seamlessly integrates with the NORD Quick Mover, which is installed on an Omron robot, allowing it to receive, hold, and drop off an object in a single operation. Additionally, the gate is equipped with sensors to detect the presence of goods at the gate.

This versatile gate serves as a fundamental standard module, enabling it to function as a flexible pick-up/drop-off point or be tailored to specific work processes. With an optimized arm spacing, these modules offer exceptional adaptability, accommodating a wide range of load sizes, from small to large items.

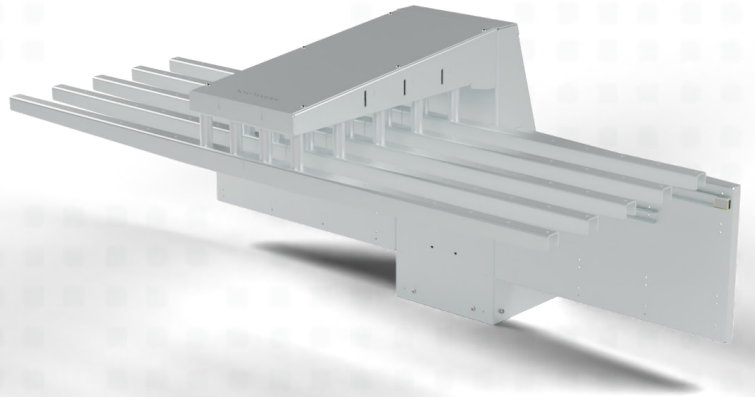

NORD compatibility



NORD QM35/65-OMRON &
NORD QM200-OMRON

OMRON compatibility



OMRON LD-60, OMRON LD-90
& OMRON LD-250

Designated use	To receive and hold, or hand off payloads from the QM
Robot compatibility	Omron LD-60, Omron LD-90 & Omron LD-250
Nord Modules compatibility	NORD QM35/65-OMRON NORD QM200-OMRON
Color	RAL 7035
Optional add-on	Sensing the presence of any payload on the gate
Max payload capacity	50 kg 110.2 lbs
Disclaimer	Specifications may vary based on local conditions and application



Simple and fast
assembly



Small
footprint



Reliable and
cost-effective



Can be customized
to specific needs



Can hold and
receive up to 50 kg

Specifications

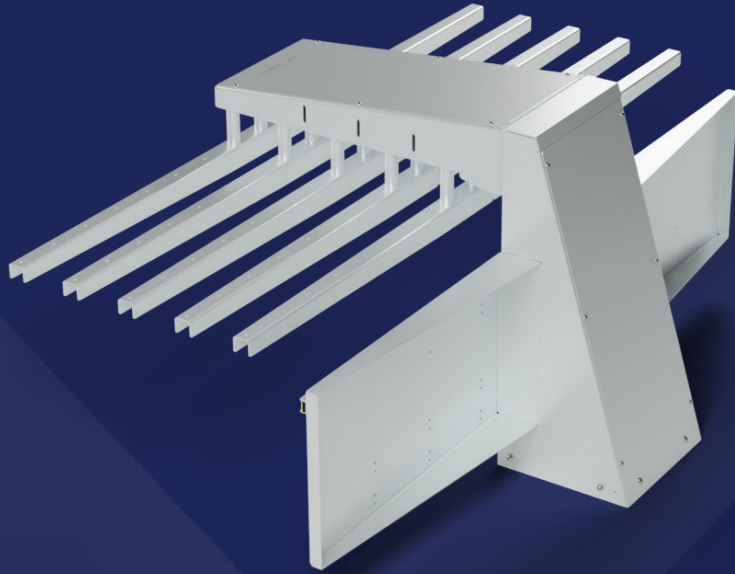

Dimensions	
Length	1 286.5 mm 50.65 in
Width	1 741 mm 68.5 in
Height	797.5 mm 31.4 in
Height to top of arms	588 mm 23.15 in
Center distance between arms	140 mm 5.5 in
Hand off & pick up area	707 x 600 mm 27.8 x 23.6 in